



# 350W General type Variable Frequency Drive with PFC function **VFD-350C-230**



## ■ Features

- 90~264Vac input, **built-in PFC function**
- Controllable with external controller
- Fanless design for no-noise and expanding life cycle
- High surge current 200% up to 5 seconds
- Protections: Short circuit/OCP
- Provided multiple sensors for control:  
Current sensor- motor torque control  
DC bus voltage sensor- OVP/UVP  
Temperature sensor - OTP
- -30~+60°C wide operating temperature
- Suitable for three phase motor drive (BLDC, Induction motor, SynRM)
- 3 years warranty

## ■ Applications

- HVAC
- Fan
- Pump
- Automatic door
- Air condition
- Conveyor
- Medical device
- Fitness equipment

## ■ GTIN CODE

MW Search: <https://www.meanwell.com/serviceGTIN.aspx>

## ■ Description

VFD-350C-230 is a variable frequency drive that can be controlled with external PWM controller. The input range is from 90VAC to 264VAC which is suitable for all kinds of installation. VFD-350C-230 able to deliver 200% peak load and with fan-less design, the life time can be extended. VFD is suitable for three-phase motor drive, such as BLDC, Induction motor, SynRM applications.

## ■ Model Encoding

**VFD - 350 C - 230**

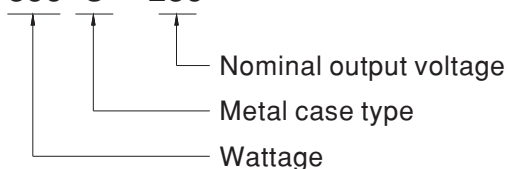

## SPECIFICATION

MODEL NO.		VFD-350C-230			
OUTPUT	VOLTAGE RANGE(UVW) <small>Note.1</small>	Three phase line-to-line 0~240V, suit for 200-240V class motor			
	OUTPUT CAPACITY	350W			
	RATED CURRENT	1.4A			
	PEAK CURRENT <small>Note.2</small>	2.8A			
	EFFICIENCY <small>Note.3</small>	93%			
	DC BUS VOLTAGE	380±5VDC			
INPUT	RATED INPUT VOLTAGE	90 ~ 264Vac			
	INPUT FREQUENCY RANGE (Hz)	47 ~ 63Hz			
	POWER FACTOR (Typ.)	PF>0.99/115VAC, PF>0.93/230VAC at full load			
	RATED INPUT CURRENT	3.5A /115VAC    2A/230VAC			
	INRUSH CURRENT	Cold start 50A			
	LEAKAGE CURRENT	<2mA/240VAC			
FUNCTION <small>(Note.5)</small>	INVERTER PWM INPUT	PWM control signal input for driving inverter IGBTs. (PIN8~13 of CN93) TTL input : IGBT ON: High(>2.6V); IGBT OFF: Low(<0.8V) ; lin =2mA			
	FAULT SIGNAL	Inverter fault signal(Short circuit/OCF, PIN7 of CN93). TTL input: Normal: High(>3V); Abnormal: Low(<0.5V)			
	DC BUS VOLTAGE SENSOR	DC BUS voltage sensor output(HV+ sensor, PIN1 of CN93): 2.5V@DC BUS 380V			
	THREE PHASE CURRENT SENSOR	Built-in 100mΩ low-side shunt resistor (each phase), (PIN4~6 of CN93)			
	THERMAL SENSOR	Built-in 10KΩ NTC for sensing IGBTs operating temperature. (TSM2A103F34D1R (Thinking Electronic), PIN2 of CN93)			
	AUXILIARY POWER VCC	Non-isolated 15V output power for user's application. Max current : 0.1A, Ripple:1V			
PROTECTION	SHORT CIRCUIT	Protection type : Shut down o/p voltage, re-power on to recover			
OUTPUT FREQUENCY	SWITCHING FREQUENCY RANGE	2.5KHz ~ 15KHz			
ENVIRONMENT	COOLING SYSTEM	Air convection			
	WORKING TEMP.	-30 ~ +60°C (Refer to "Dreating Curve")			
	WORKING HUMIDITY	20 ~ 90% RH non-condensing			
	STORAGE TEMP., HUMIDITY	-40 ~ +85°C, 10 ~ 95% RH non-condensing			
	VIBRATION	10 ~ 500Hz, 5G 10min./1cycle, period for 60min. each along X, Y, Z axes			
SAFETY & EMC	SAFETY STANDARDS	Design refer to EN61800-5			
	WITHSTAND VOLTAGE	I/P-FG:2KVAC			
	ISOLATION RESISTANCE	I/P-FG:100M Ohms/500VDC/25°C / 70%RH			
	EMC EMISSION	<b>Parameter</b>	<b>Standard</b>	<b>Test Level / Note</b>	
		Conducted	BS EN/EN IEC61800-3	Class A, C2	
		Radiated	BS EN/EN IEC61800-3	Class A, C2	
		Harmonic Current	BS EN/EN IEC61000-3-2	Class A	
		Voltage Flicker	BS EN/EN61000-3-3	-----	
	EMC IMMUNITY	BS EN/EN IEC61800-3, second environment			
		<b>Parameter</b>	<b>Standard</b>	<b>Test Level / Note</b>	
		ESD	BS EN/EN61000-4-2	Level 3, 8KV air ; Level 2, 4KV contact	
		Radiated	BS EN/EN IEC61000-4-3	Level 3	
		EFT/Burest	BS EN/EN61000-4-4	Level 3	
		Surge	BS EN/EN61000-4-5	Level 3, 2KV/Line-Earth ; Level 3, 1KV/Line-Line	
		Conducted	BS EN/EN61000-4-6	Level 3	
		Magnetic Field	BS EN/EN61000-4-8	Level 4	
		Voltage Dips and Interruptions	BS EN/EN IEC61000-4-11	>95% dip 0.5 periods, 30% dip 25 periods, >95% interruptions 250 periods	
		Voltage deviation	IEC 61000-2-4 Class 2	±10% Un	
		Total Harmonic distortion (THD)	IEC 61000-2-4 Class 3	THD 12 %	
		Individual Harmonic orders	IEC 61000-4-13 Class 3		
Frequency variations		IEC 61000-2-4	±4%		
Frequency rate of change		IEC 61000-2-4	2%/s		
OTHERS		MTBF	2078.9K hrs min.Telcordia SR-332 (Bellcore) ; 191.5K hrs min.MIL-HDBK-217F (25°C)		
	DIMENSION (L*W*H)	146*62*31mm			
	PACKING	0.38kg; 32pcs/13.18kg/0.87CUFT			
NOTE	<p>1. 3-phase 220V motor is recommended. Please consider the rated current when used for 100-120V class motor.</p> <p>2. Refer to peak load usage definition.</p> <p>3. Efficiency is tested by 350W with 150VAC output line-to-line voltage.</p> <p>4. All parameters NOT specially mentioned are measured at 230VAC input, rated load and 25°C of ambient temperature.</p> <p>5. Please refer to page 4 for more details.</p> <p>※ Product Liability Disclaimer : For detailed information, please refer to <a href="https://www.meanwell.com/serviceDisclaimer.aspx">https://www.meanwell.com/serviceDisclaimer.aspx</a></p>				

### Block Diagram

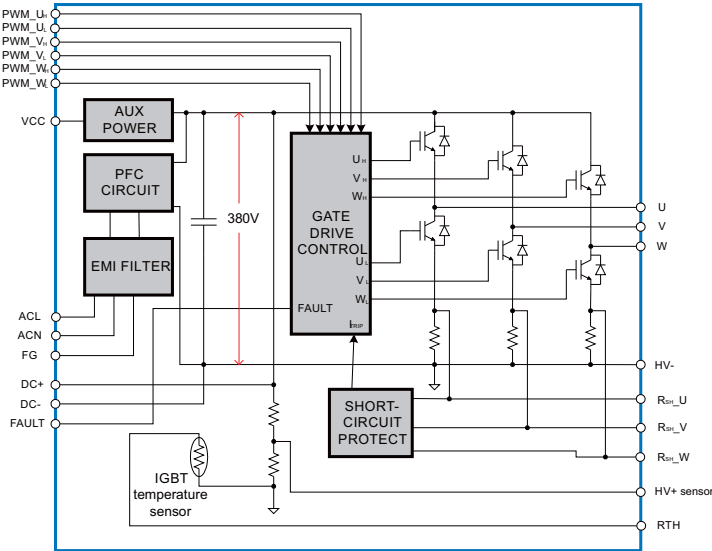

### V/I CURVE

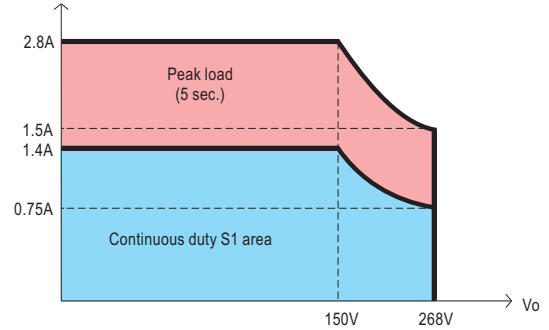

### Derating Curve



### Output Derating VS Input Voltage

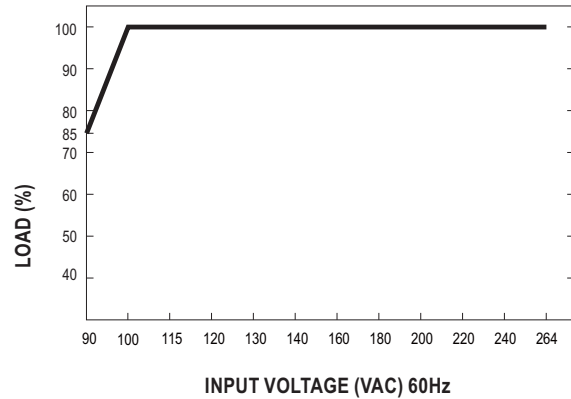

### Peak Load

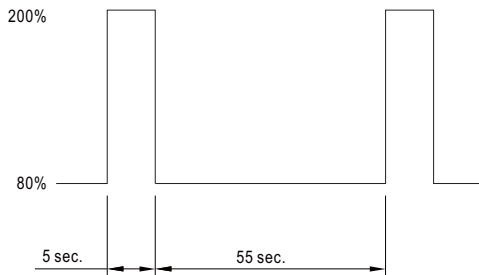

### Efficiency vs Load

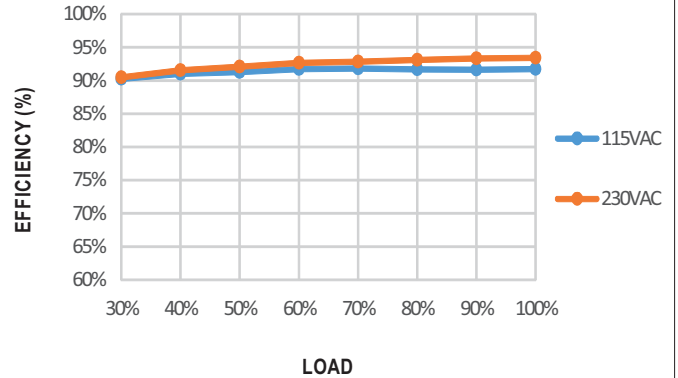

## Function Manual

### 1. 3-phase PWM Control

VFD-350C-230 provides six-switch circuit by using 3 half-bridge IGBTs. IGBTs of each phase is controlled by PWM\_U<sub>H</sub>/U<sub>L</sub>, PWM\_V<sub>H</sub>/V<sub>L</sub> and PWM\_W<sub>H</sub>/W<sub>L</sub> (PIN 8~13). The input requirement for PWM is compatible with both TTL and CMOS 3.3V signals. Please refer to the diagram below.

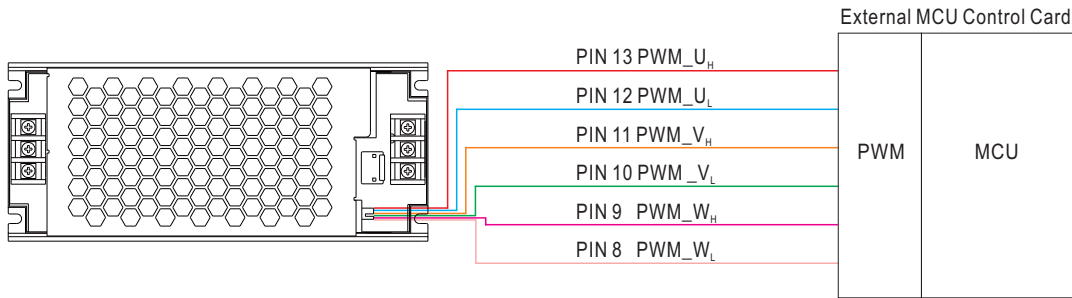

**WARNING:** It is necessary to keep minimum dead-time 300ns between the upper and lower switch of each phase.

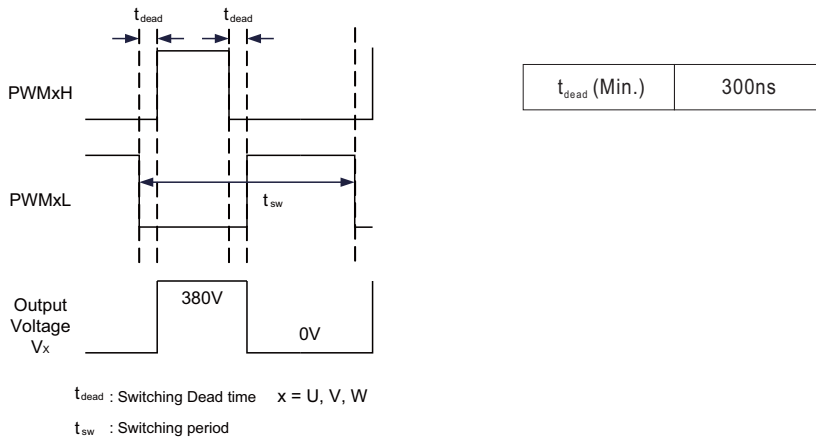

### 2. DC bus current Detection & Overcurrent Protection

Low-side shunt resistors are installed on each phase of VFD-350C-230 for current measurement and short-circuit detection. It's suggested to shorten the length of external detection circuit and detect the signal with a OPAs. Please refer to diagram below.

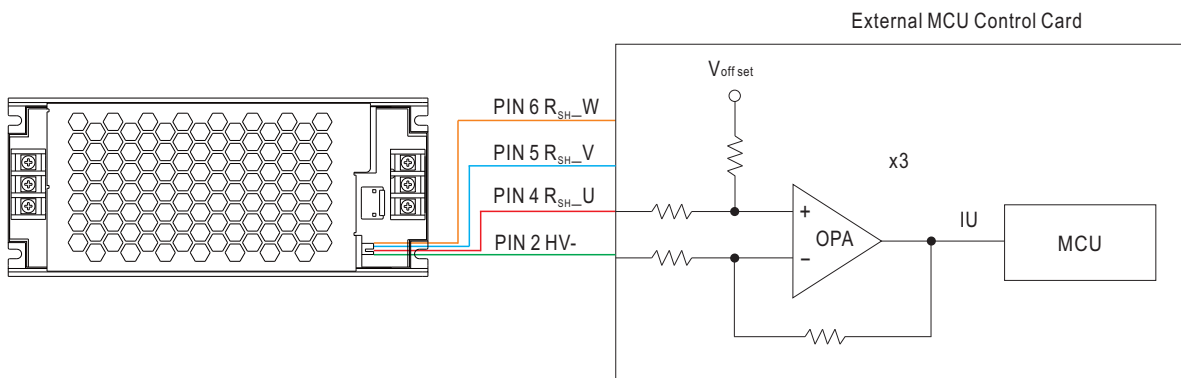

If output current exceed 200% of rated value, the protection circuit will be triggered and shut down the gate driver for protection.

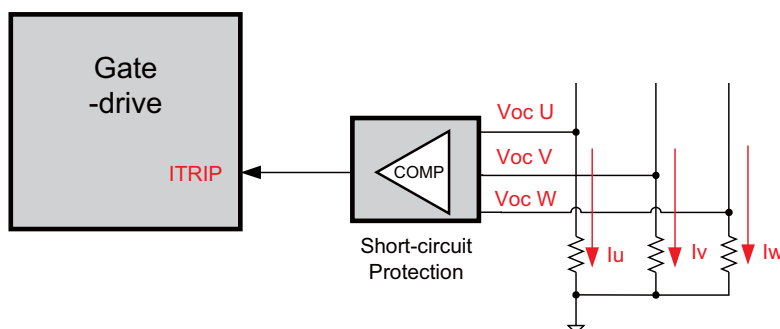

### 3. DC BUS Voltage Detection

VFD-350C-230 is built-in with DC bus voltage sensor(HV+ sensor, PIN 1). Refer to the recommended circuit. The sensor can provides a 2.5V output when DC bus voltage is at 380V. It's suggested to detect the signal by OPAs. When the voltage of the DC bus exceed 420V, the PWM input signal must shut down for protection.

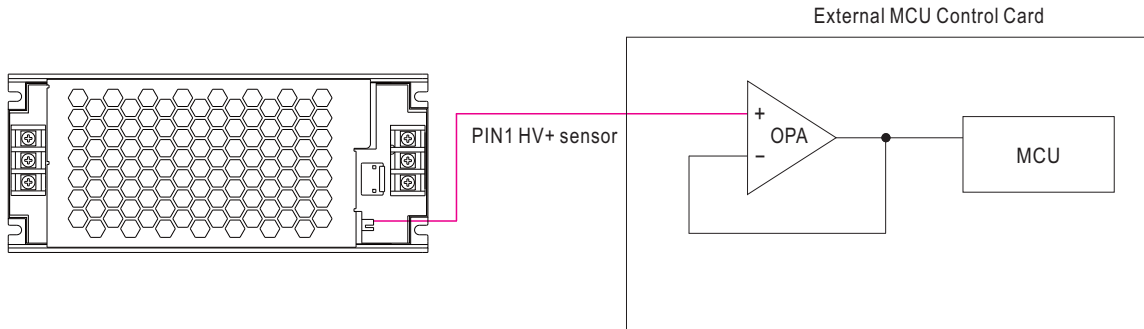

Equation for DC bus voltage calculation:

$$V_{DC\ BUS} = \frac{380 \times HV+sensor}{2.5}$$

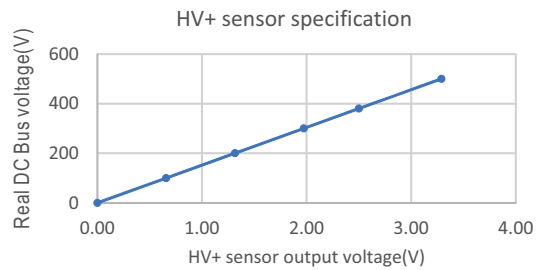

### 4. IGBT Temperature Detection

VFD-350C-230 is built-in a NTC resistor for detecting IGBTs temperature. Users can detect IGBTs temperature for protection. (NTC type: TSM2A103F34D1R, Thinking Electronic) The recommended detection circuit is below. It's suggested to shutdown the PWMs input, if the temperature is above 85°C (with conduction cooling); It's suggested to shutdown the PWMs input, if the temperature is above 100°C (with convection cooling).

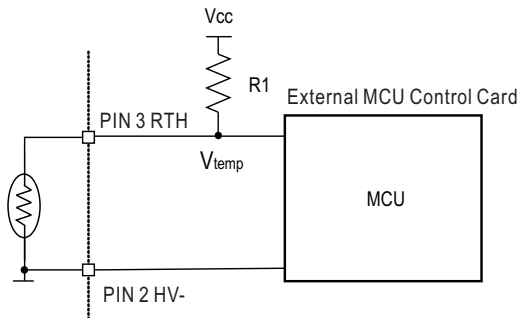

### 5. Driver Fault signal

The FAULT signal would be active(active-low) to notify external controller or circuit, if VFD-350C-230 encounter the overcurrent state and keep the state for minimum overcurrent tripping time

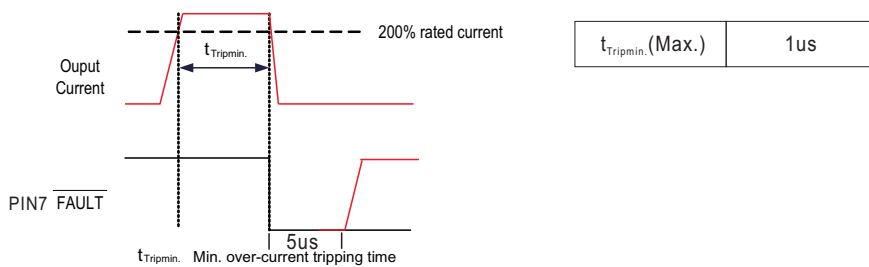

## Mechanical Specification

Case No.232G

Unit:mm

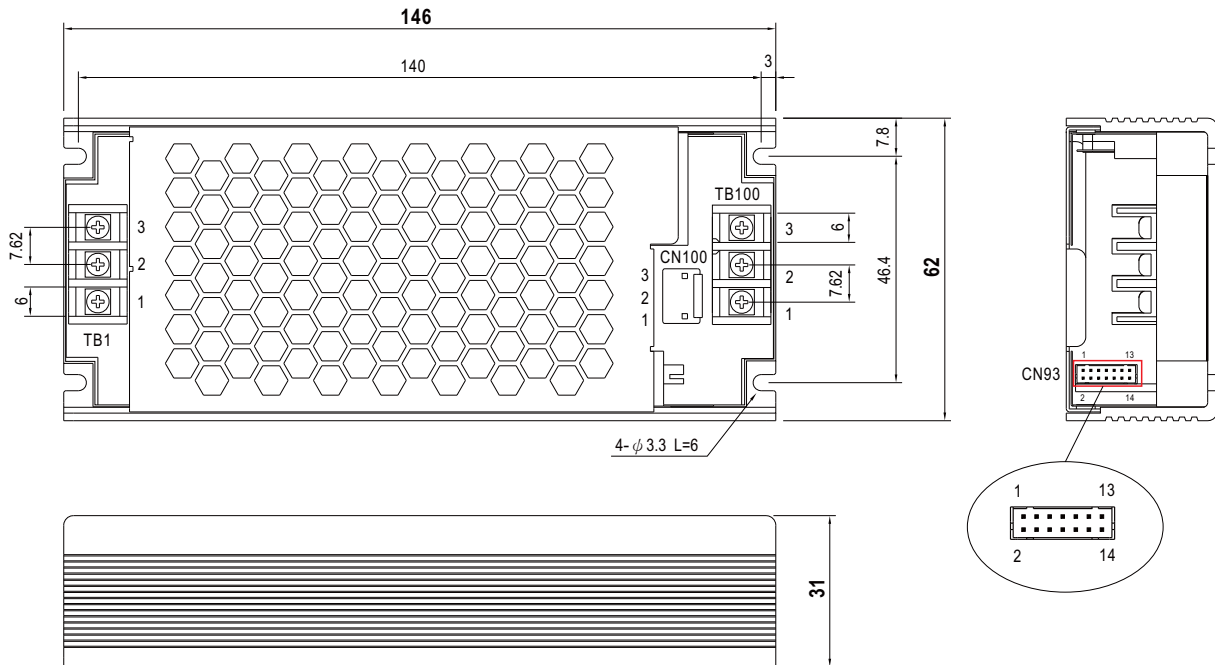

AC Input Terminal Pin NO. Assignment (TB1)

Pin No.	Assignment
1	AC/L
2	AC/N
3	⊕

Output Terminal Pin NO. Assignment (TB100)

Pin No.	Assignment
1	U
2	V
3	W

380V DC Bus Connector(CN100): JST B3P-VH or equivalent

Pin No.	Assignment
1	DC+
2	No Pin
3	DC-

Mating housing: JST VHR or equivalent

Terminal: JST SVH-21T-P1.1 or equivalent

※ CN100 is used for installing regenerative brake device, avoiding VFD-350C-230 damage.

Control Pin NO. Assignment (CN93) : HRS DF11-14DP-2DS or equivalent

Pin No.	Assignment	Pin No.	Assignment
1	HV+ sensor	8	PWM_W <sub>H</sub>
2	HV-	9	PWM_W <sub>L</sub>
3	RTH	10	PWM_V <sub>H</sub>
4	R <sub>SH-U</sub>	11	PWM_V <sub>L</sub>
5	R <sub>SH-V</sub>	12	PWM_U <sub>H</sub>
6	R <sub>SH-W</sub>	13	PWM_U <sub>L</sub>
7	FAULT	14	VCC

Mating housing: HRS DF11-14DS or equivalent

Terminal HRS DF11-\*\*SC or equivalent

※Control Pin No. Assignment(CN93) :

Pin No.	Function	Description
1	HV+ sensor	DC BUS voltage sensor output 2.5V, reference to pin 2(HV-)
2	HV-	DC BUS voltage sensor output ground
3	RTH	Temperature sensor
4	R <sub>SH-U</sub>	U phase current sensor output
5	R <sub>SH-V</sub>	V phase current sensor output
6	R <sub>SH-W</sub>	W phase current sensor output
7	FAULT	Over current detection. Normal > 3V, Abnormal < 0.5V
8	PWM_U <sub>H</sub>	W phase high side logic input, on > 2.6V ; off < 0.8V
9	PWM_U <sub>L</sub>	W phase low side logic input, on > 2.6V ; off < 0.8V
10	PWM_V <sub>H</sub>	V phase high side logic input, on > 2.6V ; off < 0.8V
11	PWM_V <sub>L</sub>	V phase low side logic input, on > 2.6V ; off < 0.8V
12	PWM_U <sub>H</sub>	U phase high side logic input, on > 2.6V ; off < 0.8V
13	PWM_U <sub>L</sub>	U phase low side logic input, on > 2.6V ; off < 0.8V
14	VCC	Auxiliary voltage output 14.5~15.5V reference to pin(HV-). The maximum load current is 0.1A

## Application

Application example: BLDC drive application

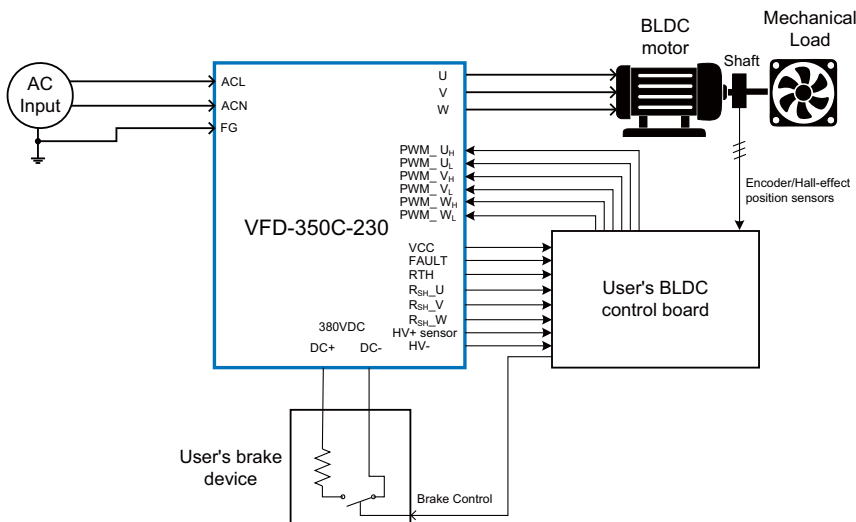

- 1.The figure shows the BLDC drive system which set up with VFD-350C-230.
- 2.Developers can control the PWM signal of 6-switch by using SPWM or SVPWM, etc. for 3-phase voltage modulation, and build the control method base on the current shunt sensors on 3-phase low-side switch(RSHU/V/W) and the DC BUS voltage sensor(HV+ sensor) which provided by VFD-350C-230.
- 3.Developers select the appropriate BLDC position sensors such as encoder or Hall-effect sensors to fit their applications.
- 4.It's suggested to install the brake circuit/device at the DC+/DC- pin( DC BUS) for avoiding the DC BUS OVP when BLDC is decelerating.
- 5.It's suggested to shut down the PWM input or connect to brake resistor device for safety when DC Bus voltage is higher than 420V.
- 6.If VFD-350C-230 were applied non-appropriate control, such as accelerating too quickly or bad current control, it might trig the VFD-350C-230's fault-state to shut down the output voltage(low-level on FAULT pin).

### 1. Operate with additional aluminum plate

In order to meet the "Derating Curve" and the "Static Characteristics", VFD series must be installed onto an aluminum plate (or the cabinet of the same size) on the bottom. The size of the suggested aluminum plate is shown as below. And for optimizing thermal performance, the aluminum plate must have an even and smooth surface (or coated with thermal grease), and VFD series must be firmly mounted at the center of the aluminum plate.

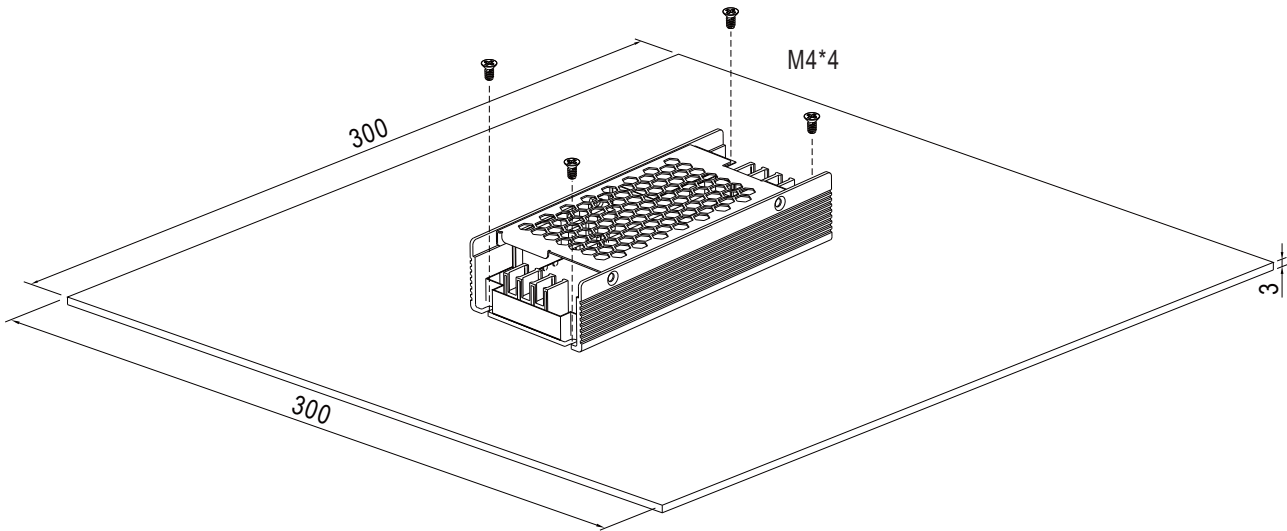

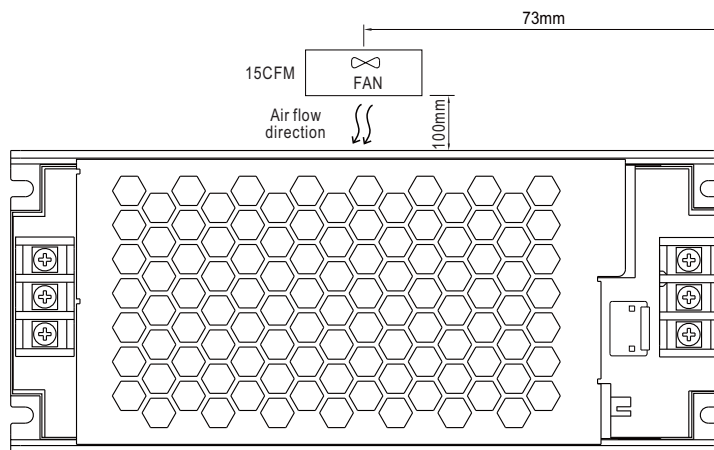

### 2. With 15CFM forced air





## ■ Accessory List

If you have any control requirement of specific application, please consult MEAN WELL for more details.

MW's order No.	Control Board	Assembly Suggestion	Quantity
VFD-CB (optional)			1

## ■ Typical Application

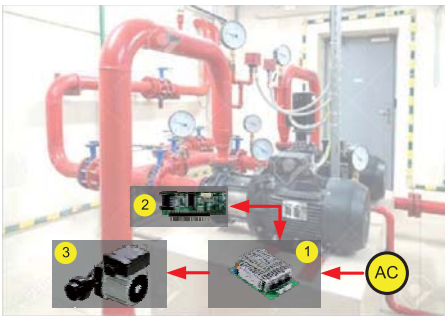

- ① Variable Frequency Module (VFD series)
- ② Control board of Variable Frequency Drive (Designed by User or Solution Provided by MEAN WELL)
- ③ Three-phase Pump Motor

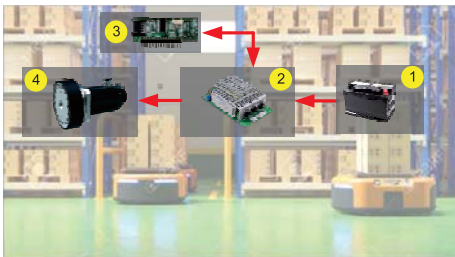

- ① Battery
- ② Variable Frequency Module (VFD series)
- ③ Control board of Variable Frequency Drive (Designed by User or Solution Provided by MEAN WELL)
- ④ Three-phase Wheel Motor for AGV Application

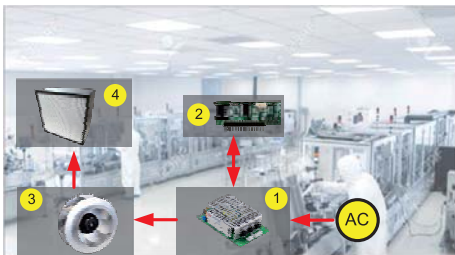

- ① Variable Frequency Module (VFD series)
- ② Control board of Variable Frequency Drive (Designed by User or Solution Provided by MEAN WELL)
- ③ Three-phase Fan Motor
- ④ HEPA for Filtering Air

## ■ Installation Manual

Please refer to : <http://www.meanwell.com/manual.html>