



FOR APPROVAL

承认书

产品名称/Type	LED 驱动器	
产品型号/Model	EDP060C0900LS	
产品编码/ Product code:	DW060C3000	
输入电压/Input voltage	<input type="checkbox"/> 100-120VAC	<input checked="" type="checkbox"/> 220-240VAC
	<input type="checkbox"/> 100-240VAC	<input type="checkbox"/> 其他 VAC
输出模式/Out type	<input checked="" type="checkbox"/> 恒流/C.C	<input type="checkbox"/> 恒压/C.V
绝缘等级/Insulation	<input type="checkbox"/> Class I	<input checked="" type="checkbox"/> Class II
防护等级/IP Grade	<input checked="" type="checkbox"/> IP20	<input type="checkbox"/> IP65 <input type="checkbox"/> IP ____
安装方式/Installation	<input checked="" type="checkbox"/> 独立式/Independent	
	<input type="checkbox"/> 内装式/built-in	
	<input type="checkbox"/> 插墙式/Plug-in	
RoHS	符合欧盟 RoHS 要求 Conform to RoHS	
客户/CUSTOMER		
客户编号/ Customer part NO.		
客户认可回签(章) AUTHORIZED SIGNATURE &COMPANY CHOP		
编制/Drew up by:	廖瑞池	日期 Date 2013.6.24
批准/Approved by:	熊川高	日期 Date 2013.6.24

EAGLERISE ELECTRIC & ELECTRONIC (CHINA) CO., LTD.

Add: Gui cheng Sci-Tech Industrial Park, Jian ping Road, Nan hai District, Fo shan City, Guang
dong Province, P.R. China

Tel: (0757) 86256772 Fax: (0757) 86256788

DZ-YF3-002-10B

一. KEY FEATURES (产品特点)

<p>▲Input(220-240VAC) (输入电压 220-240V)</p> <p>▲Protections: short circuit/over load/over voltage/over temperature (保护功能: 短路/输出过载/输出过压/过温)</p> <p>▲IP20 Protection Grade (IP20 防护等级)</p> <p>▲Power Factor (功率因数) PF\geq0.9</p> <p>▲High Efficiency (效率) \geq87%</p>	<p>Picture(产品图片)</p> 
---	---

二.ELECTRICAL SPECIFICATIONS (电气规格)

类别	Item 项目	Technical Norm 技术指标
	Max. Output Wattage (最大输出功率)	60W
Input (输入特性)	Rated input voltage(额定输入电压范围)	220-240VAC
	Range of input voltage (输入电压范围)	176-264VAC
	Frequency(Hz) (输入频率范围)	50/60 Hz
	Power Factor(功率因数)	PF\geq0.9 @Full Load,240VAC
	Input Current max (最大输入电流)	0.45A MAX. @Full Load,176VAC
	Start-up time(启动时间)	<1S @Full Load
	Unload Power Consumption(空载功耗)	\leq 1W
	Inrush Current (涌入电流)	20A MAX. @Full Load,240VAC
Output (输出特性)	Unload voltage (空载电压)	75VDC MAX.
	Voltage(VDC) (输出电压)	44-67V @176-264VAC
	Current(Convection) (输出电流) (A)	900mA @176-264VAC
	Current Accuracy (电流精度)	\pm5% @220-240VAC
	Voltage Regulation(电压调整率)	\leq 3% @Full Load
	Hold-up Time(输出保持时间)	1s max
	Current Ripple (电流纹波)	<45mA _{p-p} @Full Load,240VAC
	Recommend maximum numbers of LED in series (建议串联最大灯数量)	20PCS(V _f \leq 3.3V)
	Efficiency in full load(满载效率)	\geq87% @Full Load,240VAC
Dimming (调光)	Dimmable (调光)	NA
	Dimming mode(调光模式)	NA
	Dimming current range (调光电流范围)	NA
Protection (保护特性)	Over Load Protection (过载保护)	105-120% Protection type: Auto Resume(保护类型: 自动恢复)
	Over Voltage Protection(过压保护)	>75VDC Protection type: Auto Resume(保护类型: 自动恢复)
	Short circuit Protection(短路)	Protection type: Auto Resume(保护类型: 自动恢复)
	Over Temperature protection (过温)	Protection type: Auto Resume(保护类型: 自动恢复)
Hi-pot (耐压)	Input-Output(V.AC)(输入-输出)	3750V/5mA/1min
	Input-FG(V.AC)(输入-地)	NA
	Output-FG(V.AC)(输出-地)	NA

	Leakage Current (泄漏电流)	<0.5mA (240VAC)
Isolation resistance (绝缘阻抗)	Input-Output(V.AC)(输入-输出)	≥4MΩ@500Vdc
	Input-FG(V.AC)(输入-地)	NA
	Output-FG(V.AC)(输出-地)	NA
Environment (环境特性)	Operating Temperature(工作温度)	-10℃...+50℃
	Storage Temperature(存储温度)	-25℃...+80℃
	Humidity(湿度)	10%-95%RH
	Life time	>30,000h @50℃
Others (其它)	Dimension (尺寸)(LXWXH)	157*54*36(LXWXH)mm
Safety & EMC (安规与电磁兼容)	Approval (认证)	CE
	Safety standards (安全标准)	EN 61347-1; EN61347-2-13 EN60598-1; EN60598-2-6
	EMC standards (电磁兼容性标准)	EN55015;
		EN61000-3-2 Class C
		EN61000-3-3
EMS (电磁兼容抗扰度)	EN 61547; EN 61000-4-2 一空气放电 8KV; 接触放电 4KV; Performance Criteria B EN 61000-4-5 —1000V; Performance Criteria C	
Note (备注)	All parameters NOT specially mentioned are measured at rated input or max rated input , and 25℃ of ambient temperature(所有的参数无特别说明的都是在额定输入电压或者是额定输入电压的上限值和 25℃的环境温度下测得)	

三. MECHANICAL SPECIFICATIONS (机械规格)

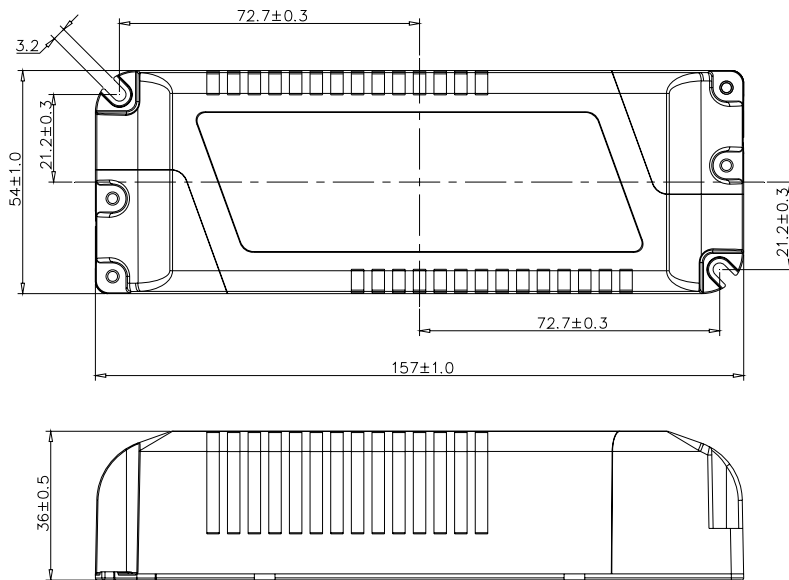

四、DESCRIPTIONS OF CHANGE (变更描述)

变更项目 ITEM	变更前 BEFORE	变更后 AFTER	版本 Version	变更日期 DATE
Current Accuracy (电流精度)	< 90mA _{p-p} @Full Load,240VAC	< 45mA _{p-p} @Full Load,240VAC	1.1	2014. 4. 11